

	degree	pulse
Joint #1 (The whole Manipulator revolves)	170 ~	8168472 pulse
Joint #2 (The lower arm swings)	-150 ~+50 ~	-9986436 pulse ~+559950 pulse
Joint #3 (The upper arm swings)	-51 ~+190 ~	-2343172 pulse ~+29652 pulse
Joint #4 (The wrist revolves)	200 ~	8046281 pulse
Joint #5 (The wrist swings)	-125 ~	-4599018 pulse
Joint #5 (The hand rotates)	-350 ~	13410155 pulse

*This drawing shows all Joint of 0 pulse position NOTE: ←degree

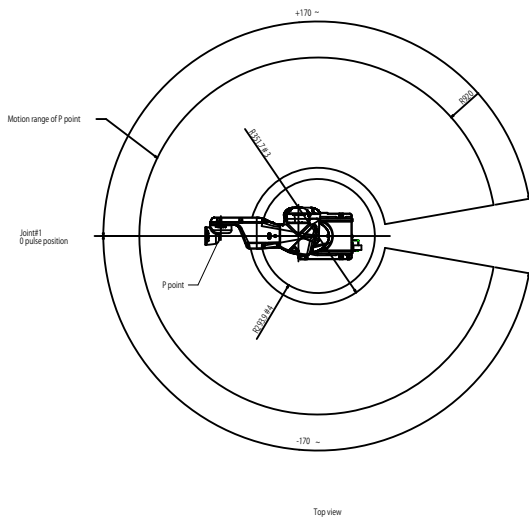
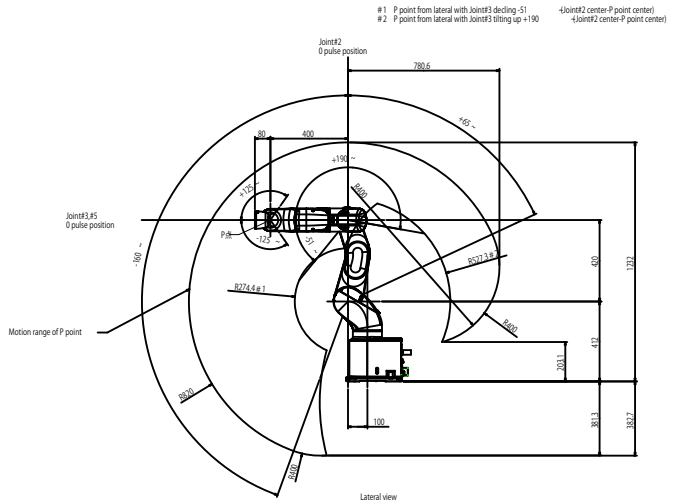
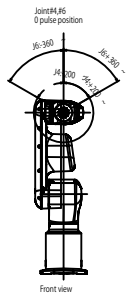

- #3 P point from top with Joint#3 declining -51 ←Joint#1 center - P point center)
- #4 P point from top with Joint#3 tilting up +190 ←Joint#1 center - P point center)